



**NY - GEO 2026**  
March 24-25, 2026 | Brooklyn, NY



# Innovative Domestic Hot Water Approach

## Speakers:

Hugh Hendersen / *Owahgena Consulting, Inc.*  
Jens Ponikau / *Buffalo Geothermal*

# M&V for NYCHA Ground Source DHW

## The Impact of System Arrangement and Controls

Hugh Henderson  
Principal, OCI

NY-GEO Conference – Brooklyn  
March 24, 2026

# M&V for NYCHA Ground Source DHW

- NYCHA hired a contractor to install ground source heat pumps in 17 multifamily facilities in the Bronx
  - a performance contract with defined efficiency goals
  - a “Top Job” presented this morning
- Putting DHW loads on a Ground Source Heat Pump System
  - Reduces the loads on the facility boilers year-round
  - Facility boilers can be shut off for 6 months per year....greatly reducing boiler idling or standby losses
- OCI conducted on-site M&V at two facilities on Sep 26, 2024 for NYSERDA
  - Jackson 3
  - Eastchester 3

# Fairly Similar Multifamily Buildings

	<b>Floor Area (sq ft)</b>	<b>Apts</b>	<b>Est Occupancy</b>	<b>Sq ft per Apt</b>	<b>Occ per Apt</b>
Jackson 3	120,050	122	375	988	3.1
Eastchester 3	111,120	112	249	992	2.2

# Comparing Jackson and Eastchester Systems

- Common Elements (same hardware)
  - Same ground loop heat exchanger and similar source-side pumping
  - Same heat pumps (two WaterFurnace NXW360)
  - Same tanks (3 pre-heat 500 gal tanks; one final 500 gal ER tank)
- Different System Arrangement
  - Jackson: 3 tanks are in parallel (traditional) & recirc into bottom inlet of all
  - Eastchester: 3 tanks are series & recirc return into bottom inlet of tank 2
- Different Load-Side Flow Control
  - Jackson: hot water flow selected for  $\sim 10^{\circ}\text{F}$  rise (traditional multi-pass)
  - Eastchester: hot water flow selected for  $40\text{-}80^{\circ}\text{F}$  rise (single-pass)

# Jackson 3 System Arrangement

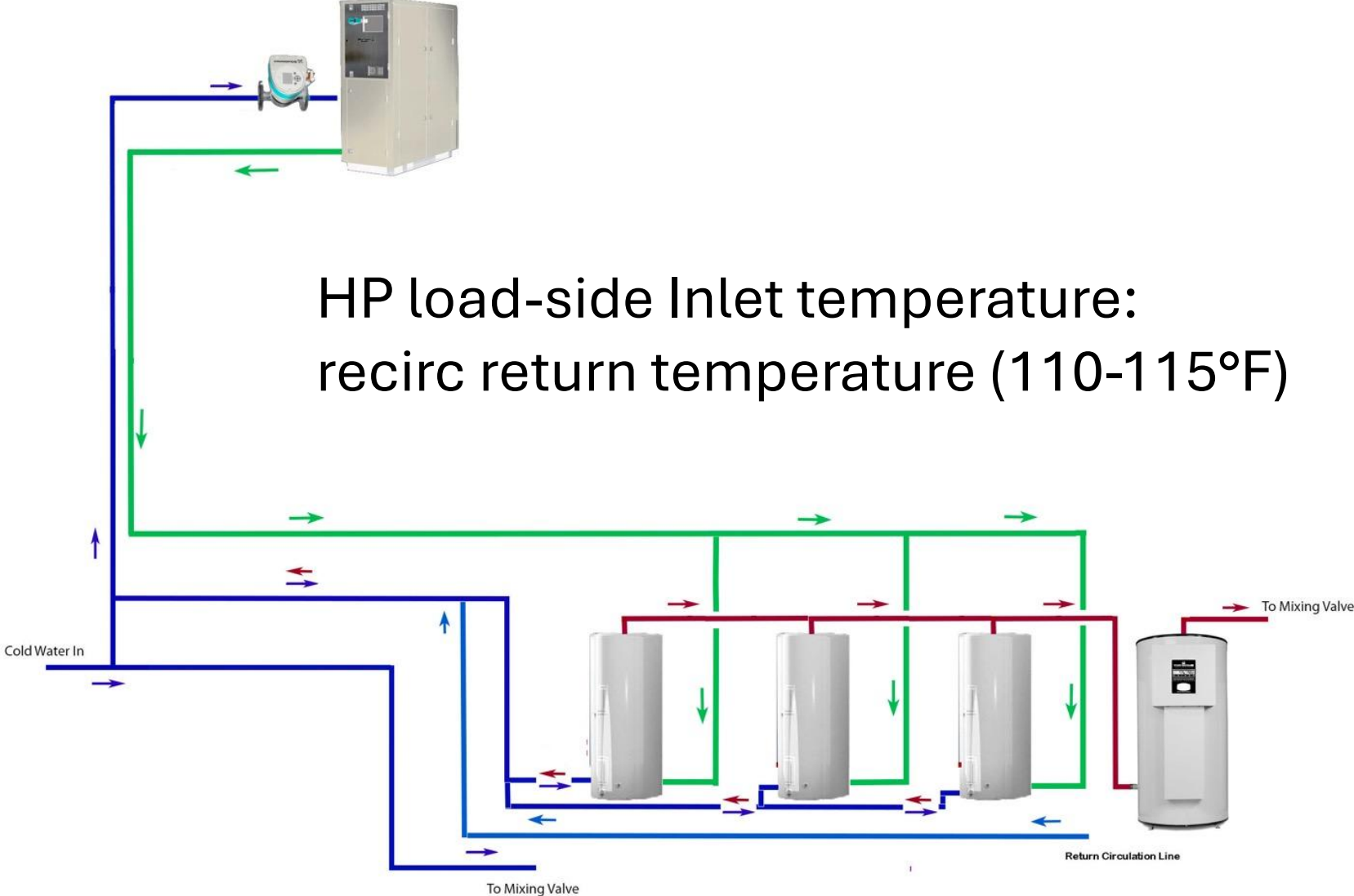

# Eastchester 3 System Arrangement

## EASTCHESTER 3

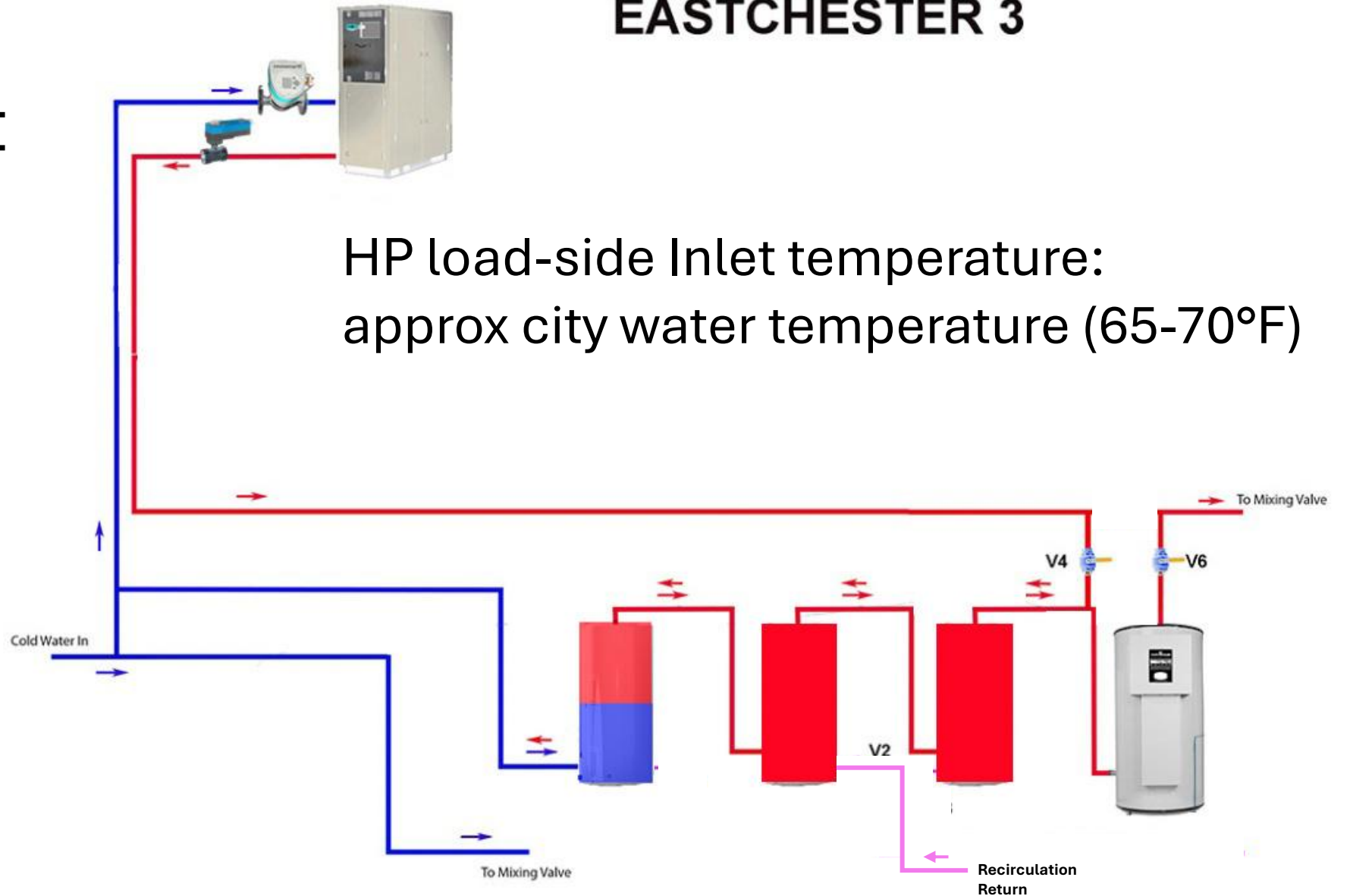



# Novel Control of HW Flow at Eastchester



HVAC Equipment

- Needed fast-acting flow control
  - Used variable speed pump AND modulating valve
  - Had to control saturated discharge temperature (SDT) so HP would not lock-out on high pressure
- Control is difficult to implement with traditional building/HVAC control systems (too slow)
  - Manufacturer did not necessarily recommend this approach
  - Buffalo Geothermal came up with novel control approach that was stable

Project: NYCHA-DHW, New York		04-03-2023- Pending Approval		
Contractor:				
Engineer:				
Representative: MWSK Equipment, New York				
<b>Performance Summary - Unit 1, Tag</b>		TruClimate 100 Domestic Hot Water Chiller (NXW) 360		383652-1
		Model Nomenclature: NXW360D3AEBNXXJ		
		Water-to-water heat pumps are an excellent choice to provide water heating and water cooling for a wide range of applications. Full Load-17.9 EER / 3.4 COP (ARI 13256-2 GLHP), Full Load-16.0 EER / 4.7 COP (ARI 13256-2 WLHP), Part Load-22.2 EER / 3.7 COP (ARI 13256-2 GLHP), Part Load-17.4 EER / 5.1 COP (ARI 13256-2 WLHP), 10 to 50 Ton, High volume hot water or chilled water.		
				
<b>General Data</b>				
<b>Voltage: 208-230/60/3</b>	Source Fluid / Antifreeze Type: Methanol	Source Fluid / Antifreeze %: 15.00	Load Fluid / Antifreeze Type: Water	Load Fluid / Antifreeze %: 0.00
<b>Heating Data</b>		<b>Source</b>		<b>Load</b>
EWT		32.00 °F		130.00 °F
LWT		26.17 °F		139.58 °F
Flow		60.00 GPM		65.00 GPM
PD		1.37 PSI 3.20 FTHD		1.80 PSI 4.20 FTHD
<b>Power</b>				<b>41.3 kW    141.0 MBTUs</b>
<b>COP</b>				<b>2.2</b>
<b>Heat Extraction</b>				<b>170.2 MBTUH</b>
<b>Heating Capacity</b>				<b>311.2 MBTUH</b>

# Jackson Control Observations

- 1<sup>st</sup> stage HP ran for 20-40 minutes
- 2<sup>nd</sup> stage HP ran for 10 minutes

LoadTemperatures.png

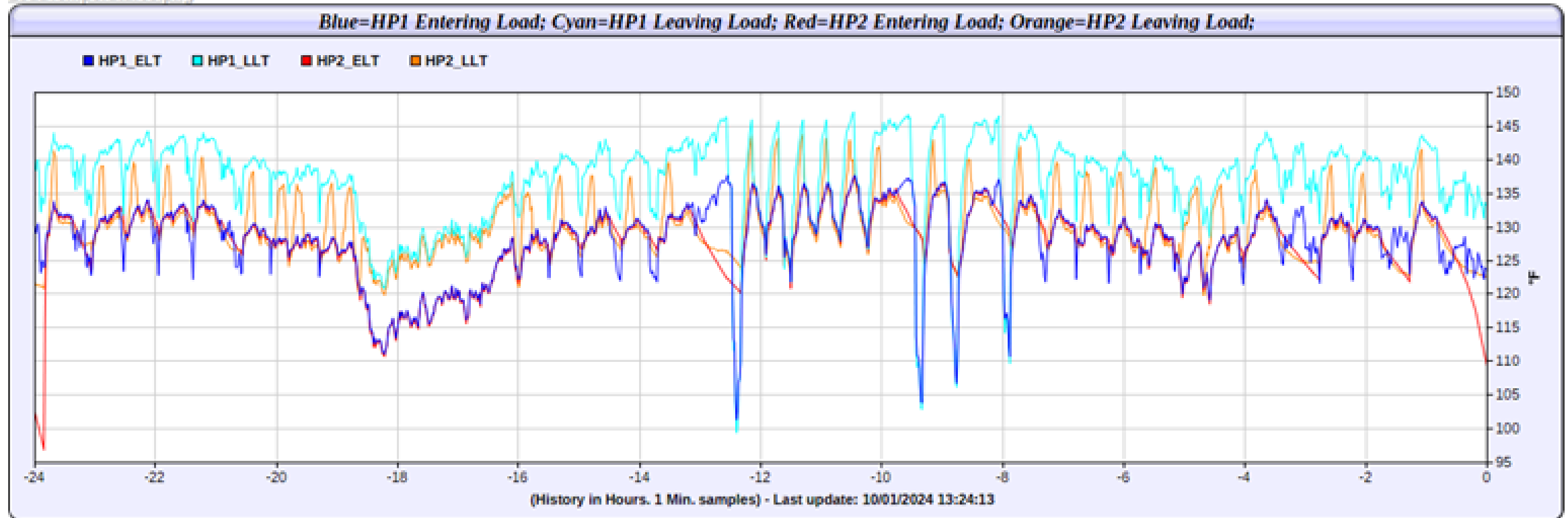

# Eastchester Control Observations

- 1<sup>st</sup> stage HP runs for 2-4 hours
- 2<sup>nd</sup> stage HP runs for short periods (mostly during high demand)

LoadTemperatures.png

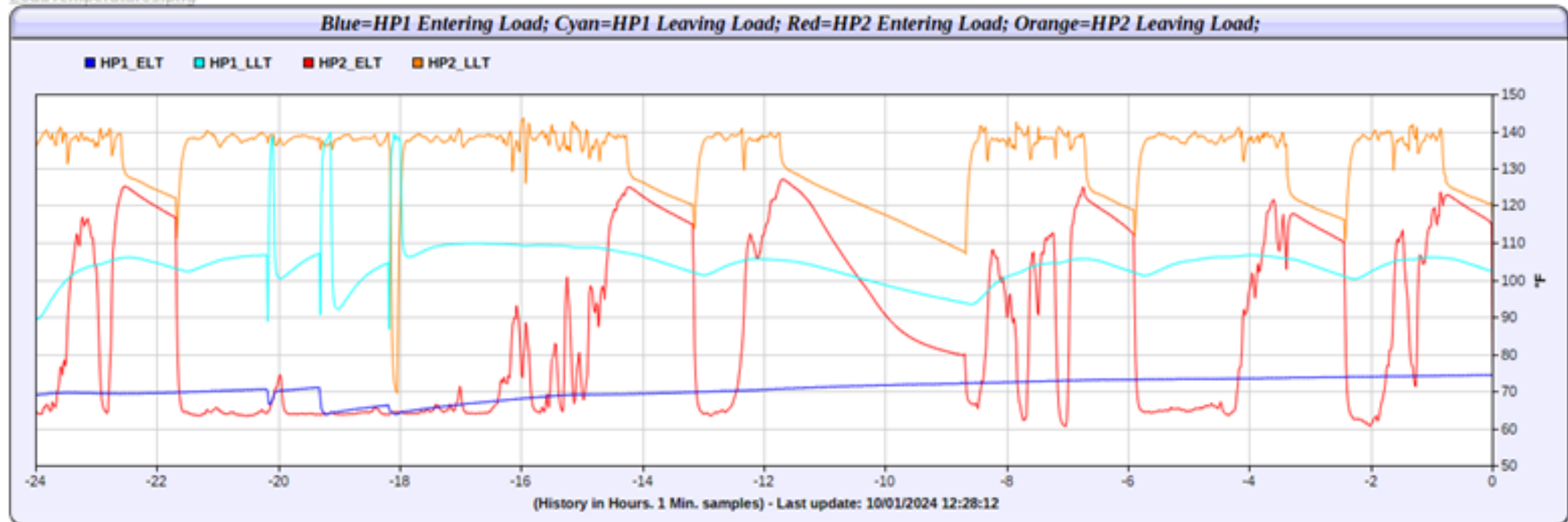

# M&V Approach

- Use sensors imbedded with heat pump controls and facility BMS
- Use ultrasonic flow meter to confirm source-side flow rates
- Use handheld true power meter (Fluke 39) to verify power readings
- Use handheld temperature insertion probe to confirm temperature readings
- Calculate heating capacity and COP

$$Q_H = Q_E + P_{OW} \quad COP = Q_H / P_{OW}$$

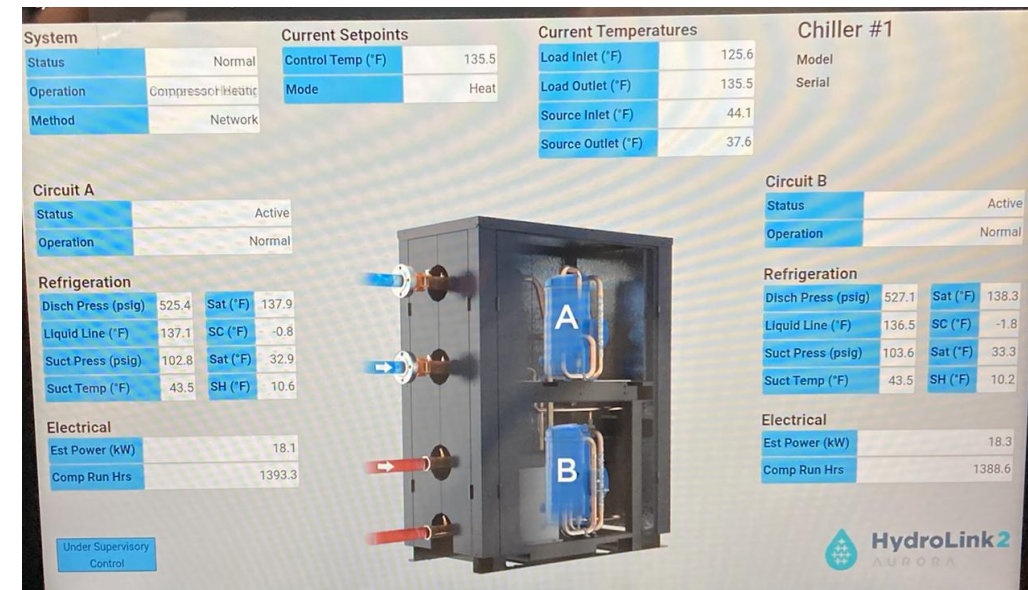

# Summary of M&V Validation

	<b>Control System</b>	<b>OCI Sensor</b>	<b>Comparison</b>	<b>Corrective Actions for Control System Data</b>
Source Flows	Willo Pump gpm	Portiflow Ultrasonic	Agreement within 3 to 6%	None
Fluid temperatures	Various WF thermistors	UEI temperature probe	Within 0.5°F at Jackson Larger errors for Eastchester	$\Delta T$ correction applied at Eastchester GHP#1 is -2°F GHP#2 is +1.9°F
Power	Water Furnace Est. kW	Fluke 39 Power Meter	Agreement within 1 to 3%	None

# Jackson Performance from M&V Spot Checks

2<sup>nd</sup> stage HP turned off for this test (therefore load out setpoint of 135°F not achieved)

Units	Load in Temp (F)	Load out Temp (F)	Sat Dist Temps (F)	Source in Temp (F)	Source out Temp (F)	Willo Pmp (gpm)	WF Pwr ( kW)	QE	QH	COP
1 WWHP			129/129	40.7	36.3	134.7	33	287.4	400.0	3.55
1 WWHP	113.9	123.7	129/129	41	36.9	133.6	33	265.7	378.3	3.36
1 WWHP	112.7	122.7	127/127	41.7	37.4	134.2	32.3	279.9	390.1	3.54
1 WWHP	113.1	122.8	127/227	41.9	37.4	133.8	32.5	292.0	402.9	3.63
1 WWHP	114.7	124.9	130/130	41.9	37.6	131.2	33.4	273.6	387.6	3.40
1 WWHP	116.6	126.1	130/130	41.9	37.6	134.7	33.4	280.9	394.9	3.47
			129.00							3.49

Load out temp (TLL) is about 4-5°F less than SDT

# Eastchester Performance from M&V Spot Checks

Unit	Load in Temp (F)	Load out Temp (F)	Sat Dist Temps (F)	Source in Temp (F)	Source out Temp (F)	Ultrasonic (gpm)	Willo Pmp (gpm)	WF Pwr (kW)	Satec Pwr (kW)	QE	QH	COP
Set Pt = 143												
GHP#2	64.2	136.8	120/123	41.9	38.8	115.5	122.3	30.7	30.9	296.6	401.3	3.83
GHP#2	70.3	137.7	122/124	41.9	38.3	119.3	126.3	31	30.9	336.9	442.7	4.19
GHP#2	65.3	138	125/123	41.9	38.3	121.8	129.8	30.7	30.95	346.2	451.0	4.31
GHP#2	64	139.1	122/124	41.7	38.5	124.7	130.8	30.9	30.9	323.5	429.0	4.07
Set Pt = 133												
GHP#2	64.2	128.9	115/118	45.5	38.3	65.2	71	29.4		313.4	413.7	4.12
GHP#2	64	128.9	115/118	45.7	38.3	66.1	72.1	29.3		325.2	425.2	4.25
GHP#2	64	128.3	115/118	45.7	38.3	65.6	70.3	29.4		317.1	417.4	4.16
GHP#2	63.9	128.6	116/118	45.9	38.3	65.7	72	29.3		331.7	431.7	4.32
Set Pt = 133												
GHP#1	64.2	130.6	117/118	45.8	36	67.7	74.2	29.9		280.7	382.7	3.75
GHP#1	64.2	130.6	117/118	45.8	36.2	69	75	30		276.5	378.8	3.70
GHP#1	65.4	130.8	117/119	45.6	36.2	70.7	78.5	30.2		281.7	384.8	3.73
GHP#1	65.1	130.3	117/118	45.4	36.2	73	81.8	29.8		285.6	387.3	3.81
Set Pt = 128												
GHP#1	64.5	121.8	112/113	45.1	36.7	90.6	98	28.7		304.2	402.1	4.11
GHP#1	64.5	122	112/113	45.1	37.1	90.9	99.1	28.6		288.4	386.0	3.96
GHP#1	64.2	121.8	112/113	45.1	37.1	91.3	99	28.5		288.1	385.3	3.96
GHP#1	64.3	121.8	112/113	44.9	37.1	93	99.4	28.6		279.6	377.2	3.87

Load out temp (TLL) is about 10-15°F greater than SDT

# Eastchester Performance for GHP#1 & GHP#2

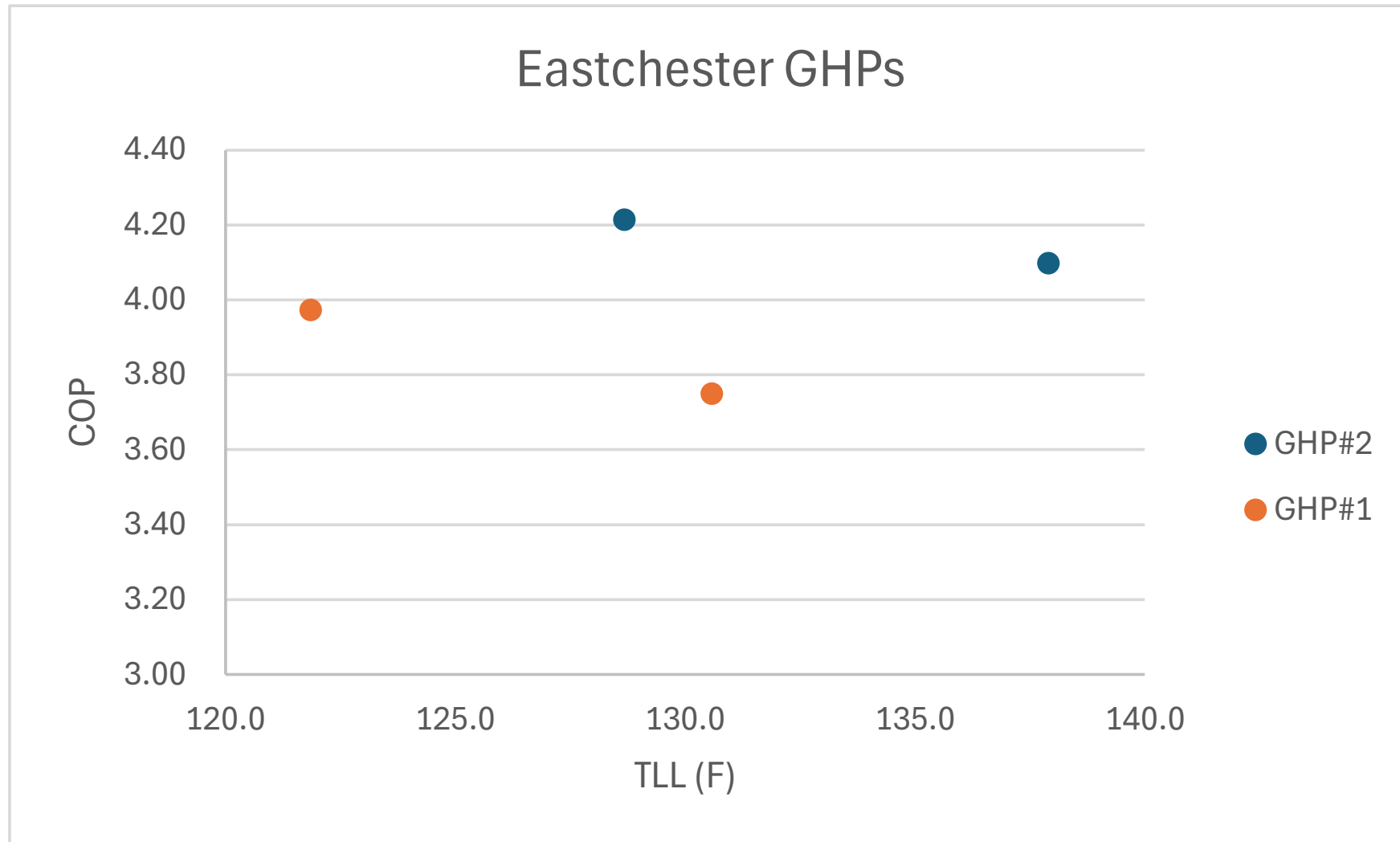

# Longer-term Trends at Eastchester (9 days of 1-min data)

	Power 1 (kWh)	Power 2 (kWh)	QH1 (MBtu)	QH2 (MBtu)	COP 1	COP 2
9/24/2024	31.4	472.1	333.7	6,220.8	3.1	3.9
9/25/2024	24.1	522.5	255.4	6,954.3	3.1	3.9
9/26/2024	37.6	428.7	458.9	5,746.1	3.6	3.9
9/27/2024	-	482.5	-	6,986.7	-	4.2
9/28/2024	51.9	516.1	554.9	7,055.0	3.1	4.0
9/29/2024	29.4	509.4	327.6	6,787.2	3.3	3.9
9/30/2024	22.0	539.3	223.7	7,348.6	3.0	4.0
10/1/2024	46.8	483.8	511.9	6,487.0	3.2	3.9
10/2/2024	58.2	479.6	651.5	6,770.7	3.3	4.1

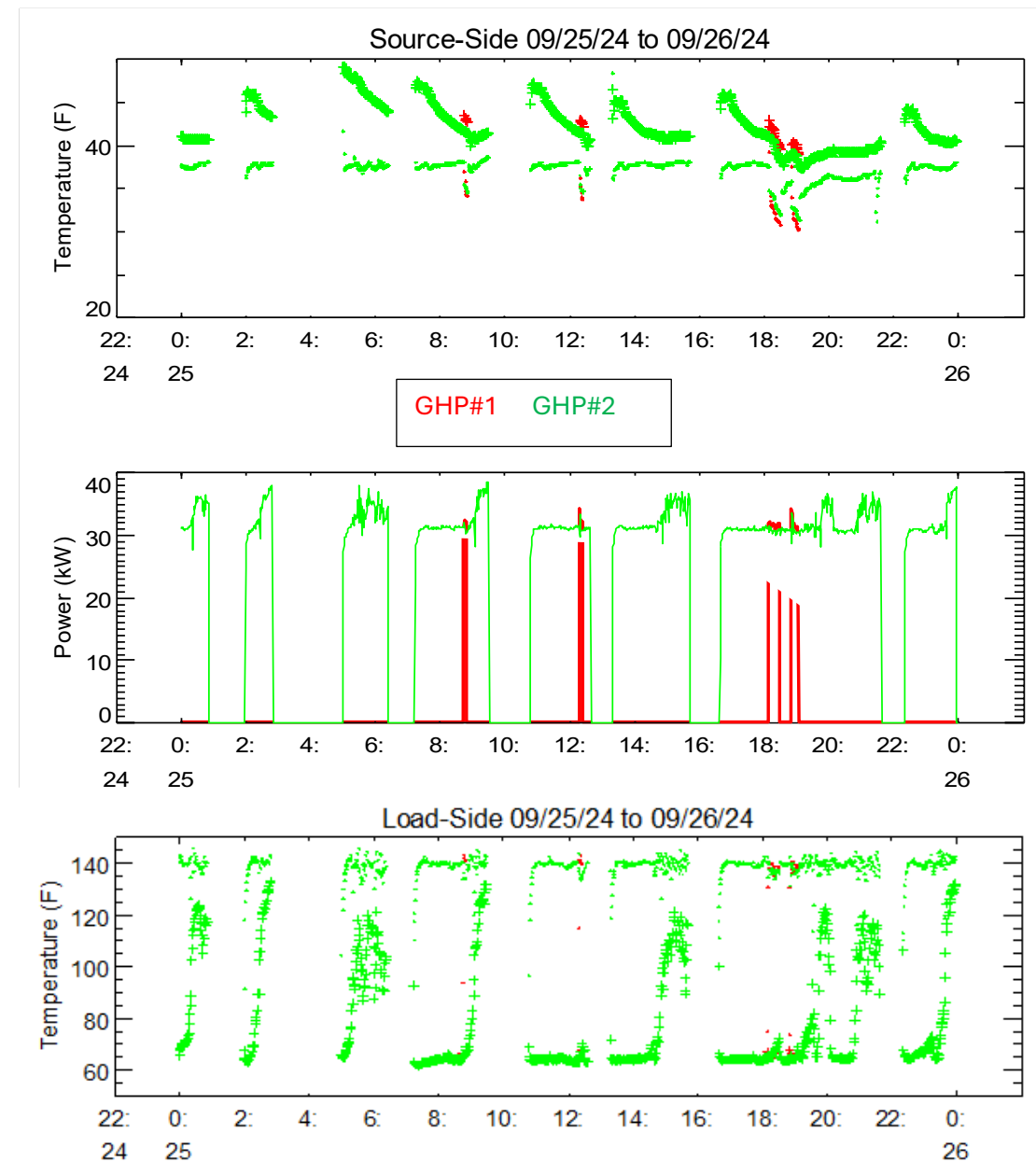

# COPs are Proportional to SDT (not TLL)

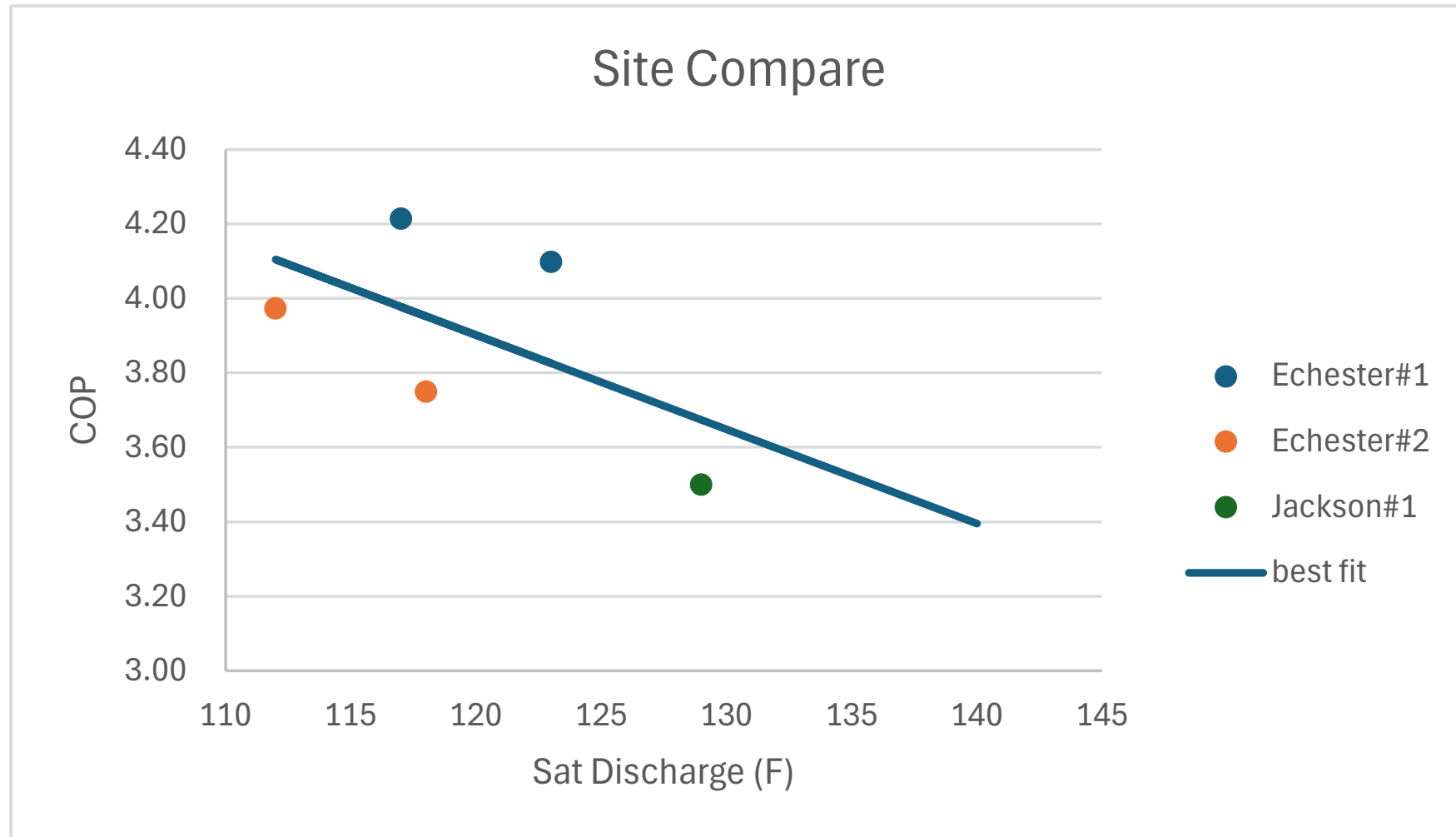

# Comparing Sites at Same Conditions (TLL=135°F)

	<b>SDT</b>	<b>Diff = TLL-SDT</b>	<b>TLL (F)</b>	<b>Unit COP (-)</b>	<b>Source Pmp (bhp)</b>	<b>Load Pmp (bhp)</b>	<b>Pumping (kW)</b>	<b>System COP (-)</b>
Jackson	140	-5	135	3.4	3.94	1.00	3.69	3.1
Eastchester	122.5	12.5	135	3.8	0.7	0	0.52	3.8

System COP is 23% higher at Eastchester

This estimate does not include savings from less tank turnover/losses!

# Conclusions

- Series arrangement of tanks means lower entering load-side temperatures to the HP which means higher COP
- Lower load-side flow rates – even on a conventional multi-pass HP – can result in single pass performance and leaving load temperatures (TLL) that are 15-20°F higher at a given SDT.
- We found a 23% higher COP from arrangement and controls based on our one-day, snapshot analysis
- This does NOT include the savings expected from less tank churn (and therefore lower standby by losses) with the series tank/low flow arrangement. Zero Place showed these can be another 10-20%.

# Innovation in DHW making

Jens Ponikau

Certified Geothermal Designer (CGD)

President, New York Geothermal Energy Organization

Buffalo Geothermal LLC



# Jackson Houses, Bronx NY



# Specified Efficiency of Geothermal Heat Pumps (Colmac Brand)

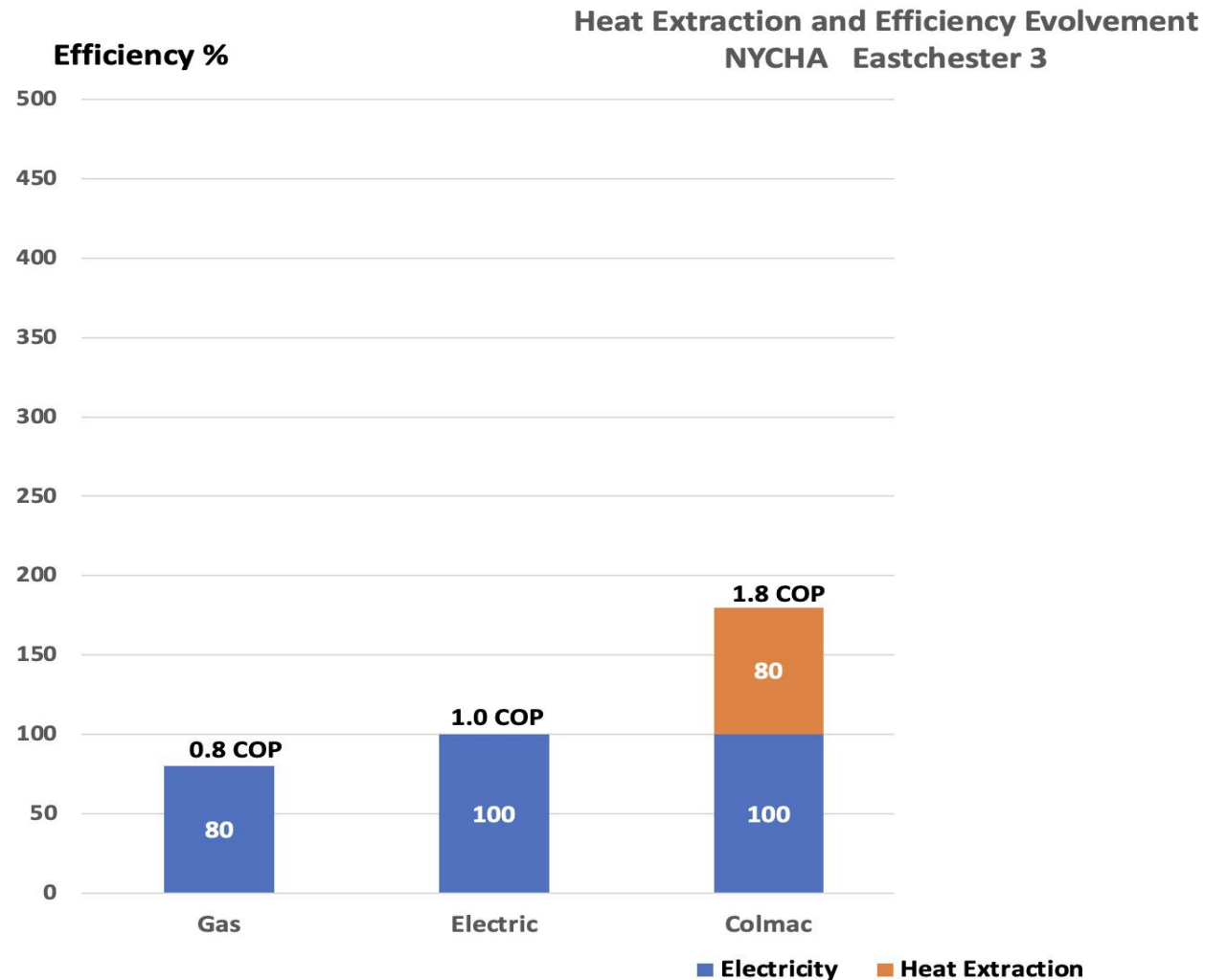

# Waterfurnace Development Lab Fort Wayne Indiana





# Waterfurnace DHW NYCHA Prototype



# Double Wall Heat Exchanger For Portable Water

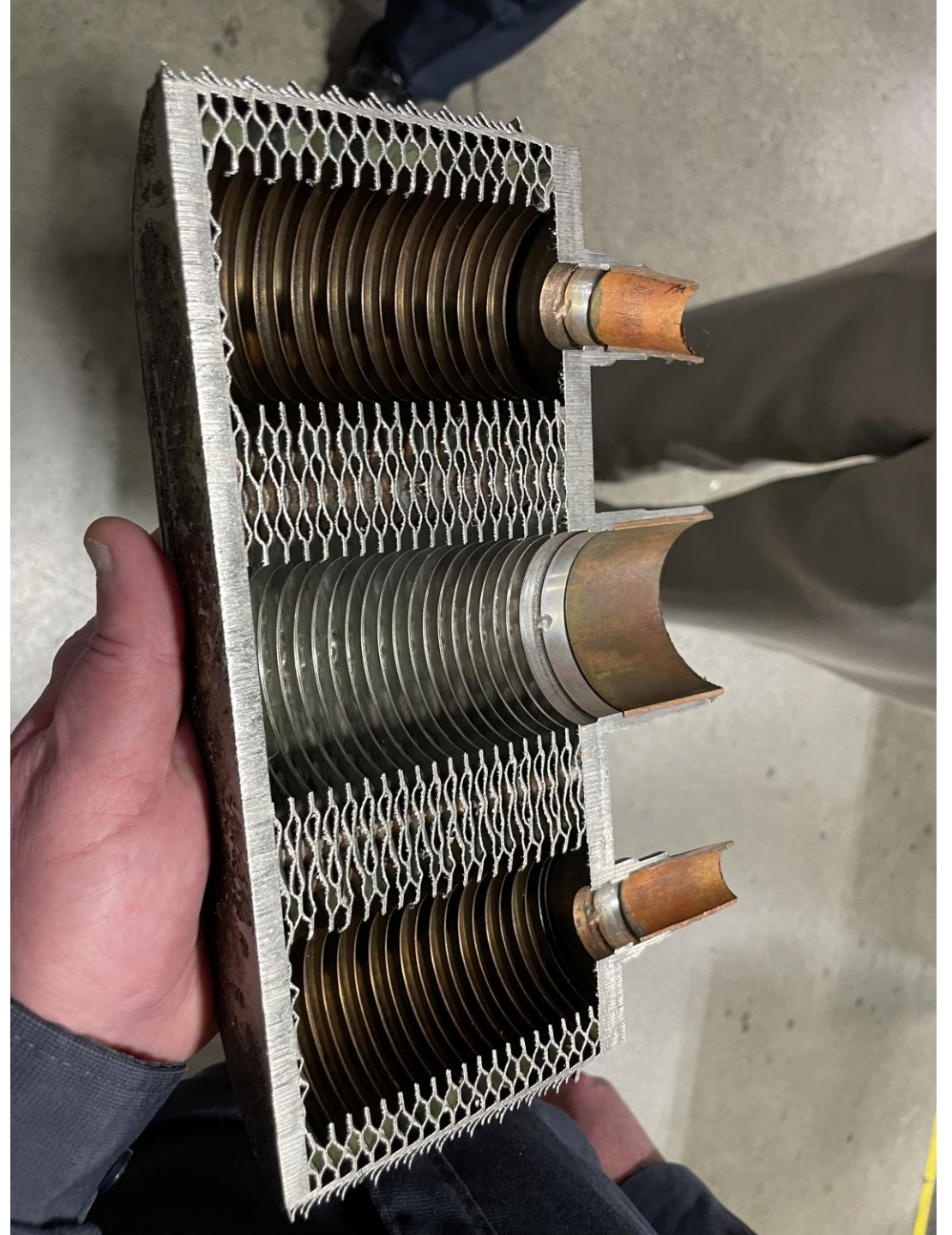

# Efficiency Improvement with Liquid Injection Unit

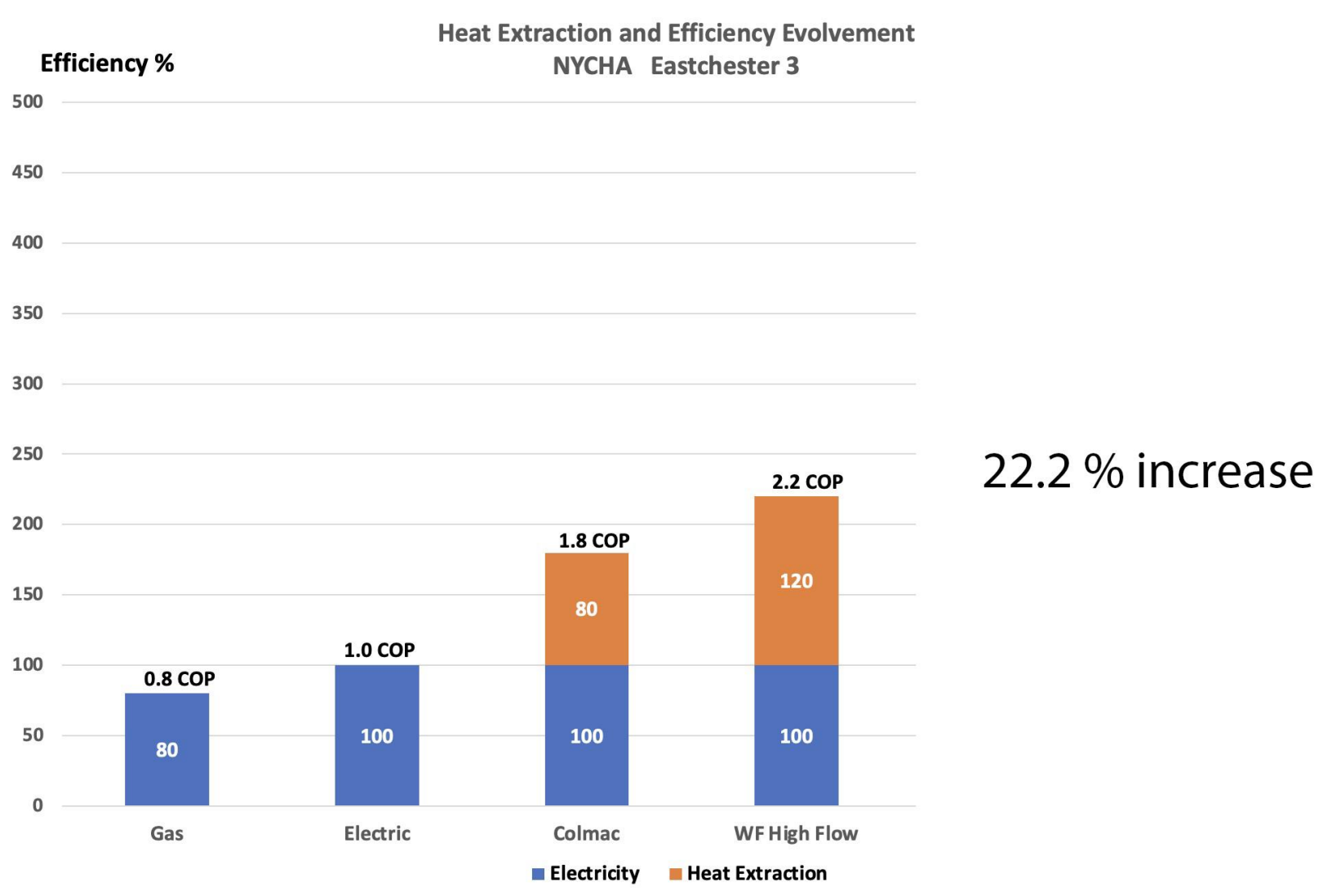

# NYCHA Heat Pump Production



# NYCHA Heat Pump Production



# Liquid Injection Compressor



# Double Wall Heat Exchanger

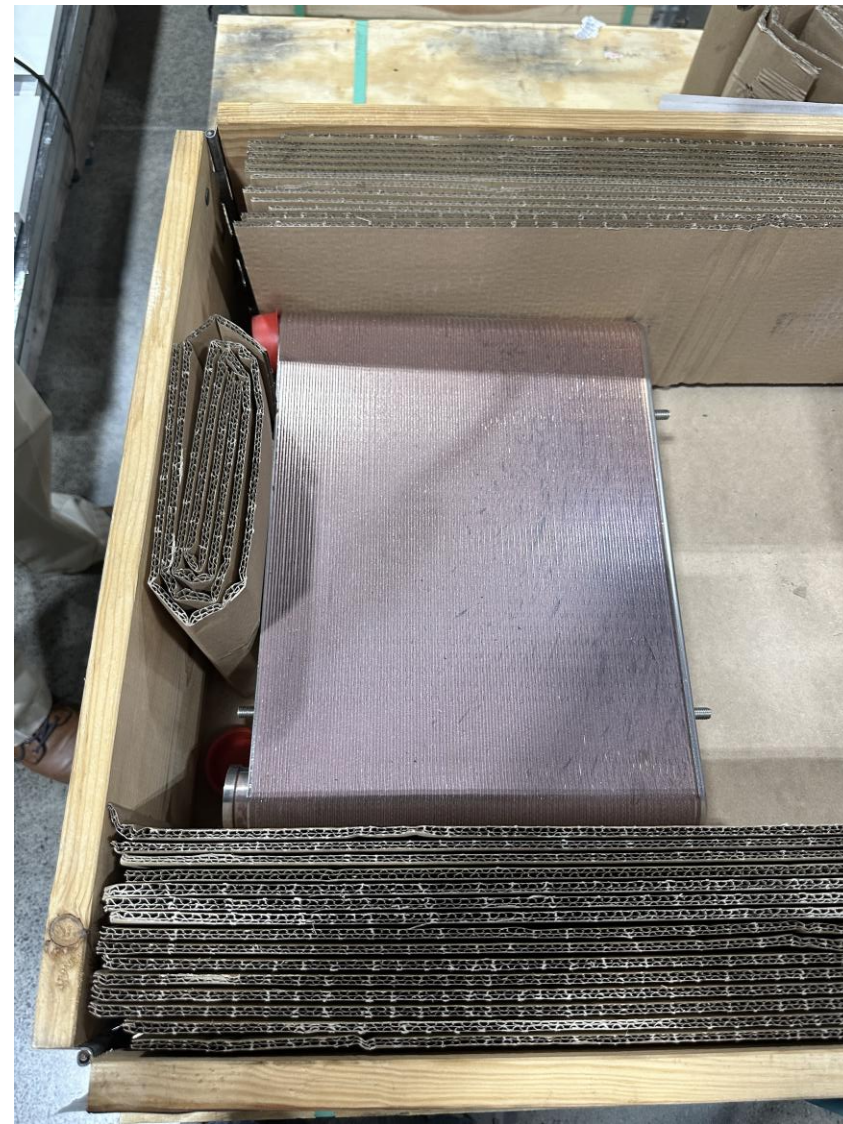

# Conventional Operations (parallel multi-pass design)

System
Overviews ▾ Settings Diagnostics
Refresh

### System

Status	Normal
Operation	al Compressor Hee
Method	AquaStat

### Current Setpoints

Control Temp (°F)	148.2
Mode	Heat

### Current Temperatures

Load Inlet (°F)	136.8
Load Outlet (°F)	148.2
Source Inlet (°F)	52.0
Source Outlet (°F)	46.0

Model NXW360D3AEBNRRUJ  
Serial 231001638

### Circuit A

Status	System Disabled
Operation	Normal

### Circuit B

Status	System Disabled
Operation	Normal

### Refrigeration

Disch Press (psig)	599.8	Sat (°F)	148.8
Liquid Line (°F)	148.2	SC (°F)	-0.6
Suct Press (psig)	124.2	Sat (°F)	42.7
Suct Temp (°F)	51.7	SH (°F)	9.0

### Refrigeration

Disch Press (psig)	601.5	Sat (°F)	149.0
Liquid Line (°F)	147.2	SC (°F)	-1.8
Suct Press (psig)	123.9	Sat (°F)	42.5
Suct Temp (°F)	51.7	SH (°F)	9.2

### Electrical

Est Power (kW)	21.0
Comp Run Hrs	3.5

### Electrical

Est Power (kW)	20.6
Comp Run Hrs	3.4





# Serial single-pass instant heat pump hot water heater

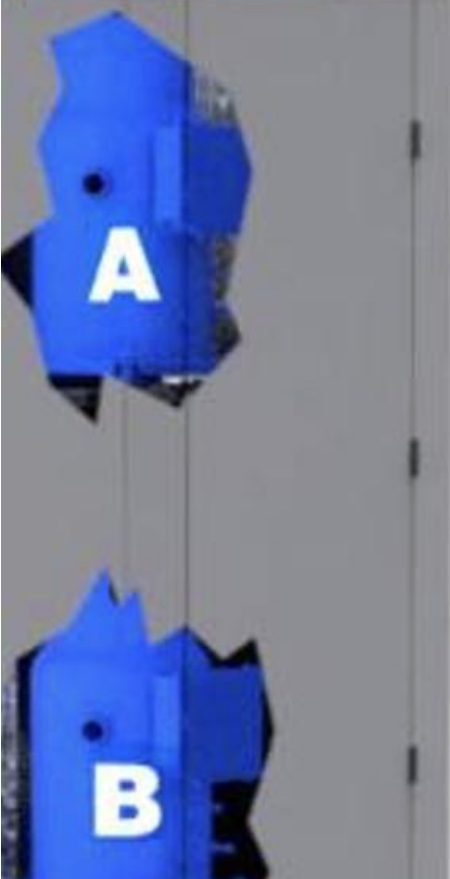

**Current Temperatures**

Load Inlet (°F)	46.3
Load Outlet (°F)	153.4
Source Inlet (°F)	30.7
Source Outlet (°F)	24.3

**Chiller #1**

Model  
Serial

**Circuit B**

Status	Active
Operation	Normal

**Refrigeration**

Disch Press (psig)	438.5	Sat (°F)	123.9
Liquid Line (°F)	85.2	SC (°F)	-38.7
Suct Press (psig)	74.7	Sat (°F)	17.9
Suct Temp (°F)	26.8	SH (°F)	8.9

**Electrical**

Est Power (kW)	16.6
Comp Run Hrs	119.6

# Low Flow Scenario Efficiency gain

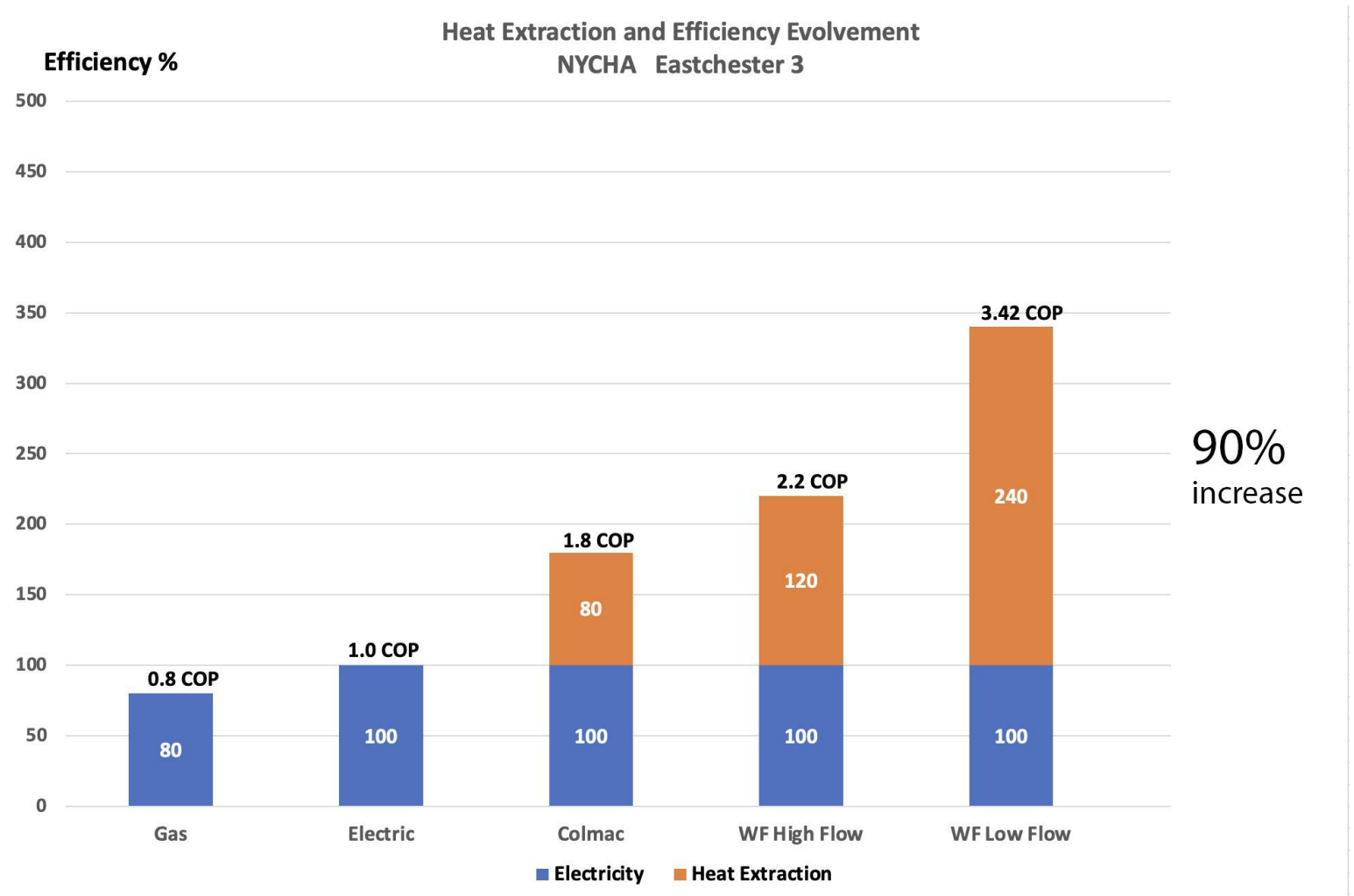

# Significantly improved performance at high temperatures

System    Overviews ▾    Settings    Diagnostics    Refresh

**System**

Status	Normal
Operation	Compressor Heating
Method	AquaStat

**Current Setpoints**

Control Temp (°F)	140.4
Mode	Heat

**Current Temperatures**

Load Inlet (°F)	43.9
Load Outlet (°F)	147.6
Source Inlet (°F)	54.4
Source Outlet (°F)	46.2

Model NXW360D3AEBNNRUJ  
Serial 231001638

**Circuit A**

Status	System Disabled
Operation	Normal

**Refrigeration**

Disch Press (psig)	461.9	Sat (°F)	127.9
Liquid Line (°F)	126.5	SC (°F)	-1.4
Suct Press (psig)	126.6	Sat (°F)	43.7
Suct Temp (°F)	49.4	SH (°F)	5.5

**Electrical**

Est Power (kW)	15.6
Comp Run Hrs	3.5

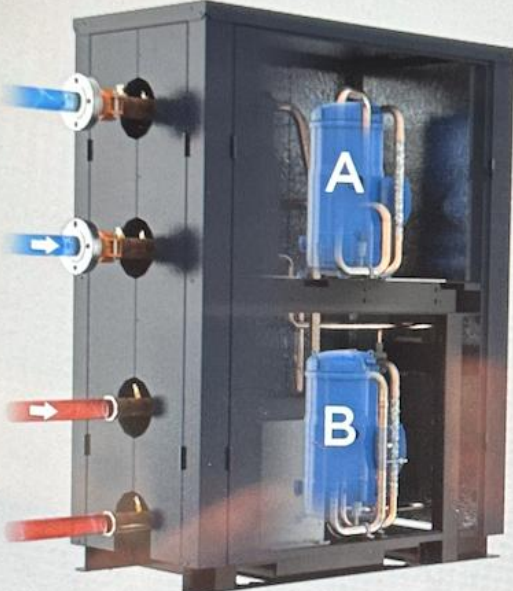

**Circuit B**

Status	System Disabled
Operation	Normal

**Refrigeration**

Disch Press (psig)	467.0	Sat (°F)	128.7
Liquid Line (°F)	125.3	SC (°F)	-3.4
Suct Press (psig)	126.6	Sat (°F)	43.7
Suct Temp (°F)	49.9	SH (°F)	6.2

**Electrical**

Est Power (kW)	15.8
Comp Run Hrs	3.5



# What is the potential....?

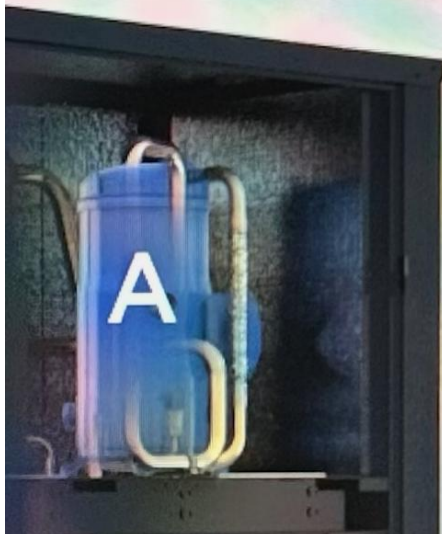

**Current Temperatures**

Load Inlet (°F)	64.5
Load Outlet (°F)	164.7
Source Inlet (°F)	49.2
Source Outlet (°F)	38.1

Model NXW360D3AEBNNRUJ  
Serial 231001638

**Circuit B**

Status	Active
Operation	Normal

**Refrigeration**

Disch Press (psig)	451.1	Sat (°F)	125.0
Liquid Line (°F)	135.3	SC (°F)	9.7
Suct Press (psig)	103.9	Sat (°F)	33.5
Suct Temp (°F)	44.4	SH (°F)	10.9

# What is the potential....?



**Current Temperatures**

Load Inlet (°F)	47.6
Load Outlet (°F)	181.3
Source Inlet (°F)	38.1
Source Outlet (°F)	30.6

Model NXW360D3AEBNNRYJ  
Serial 231002188

**Circuit B**

Status	Active
Operation	Normal

**Refrigeration**

Disch Press (psig)	579.7	Sat (°F)	146.0
Liquid Line (°F)	126.5	SC (°F)	-19.5
Suct Press (psig)	87.3	Sat (°F)	25.1
Suct Temp (°F)	37.9	SH (°F)	12.8

**Electrical**

Est Power (kW)	19.5
Comp Run Hrs	1026.1

# What is the potential....?

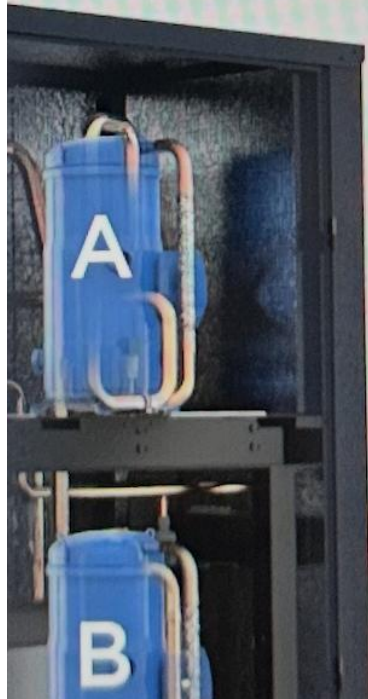

**Current Temperatures**

Load Inlet (°F)	47.4
Load Outlet (°F)	186.1
Source Inlet (°F)	38.1
Source Outlet (°F)	30.8

Model NXW360D3AEBNNRYJ  
Serial 231002188

**Circuit B**

Status	Active
Operation	Normal

**Refrigeration**

Disch Press (psig)	590.6	Sat (°F)	147.4
Liquid Line (°F)	127.2	SC (°F)	-20.0
Suct Press (psig)	87.3	Sat (°F)	25.1
Suct Temp (°F)	37.9	SH (°F)	12.8

**Electrical**

Est Power (kW)	19.7
Comp Run Hrs	1026.1

# What is the potential....?

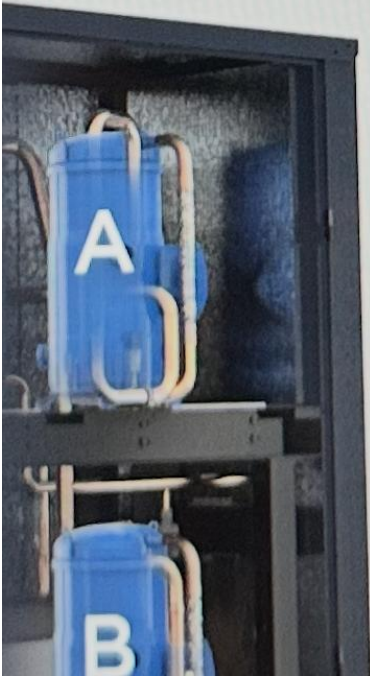

**Current Temperatures**

Load Inlet (°F)	47.6
Load Outlet (°F)	191.3
Source Inlet (°F)	38.1
Source Outlet (°F)	30.8

Model NXW360D3AEBNNRYJ  
Serial 231002188

**Circuit B**

Status	Active
Operation	Normal

**Refrigeration**

Disch Press (psig)	599.8	Sat (°F)	148.8
Liquid Line (°F)	128.8	SC (°F)	-20.0
Suct Press (psig)	87.8	Sat (°F)	25.3
Suct Temp (°F)	37.9	SH (°F)	12.6

**Electrical**

Est Power (kW)	20.0
Comp Run Hrs	1026.1

# Do you want more....?



**Current Temperatures**

Load Inlet (°F)	47.4
Load Outlet (°F)	197.2
Source Inlet (°F)	38.1
Source Outlet (°F)	31.0

Model NXW360D3AEBNNRYJ  
Serial 231002188

**Circuit B**

Status	Active
Operation	Normal

**Refrigeration**

Disch Press (psig)	606.5	Sat (°F)	149.7
Liquid Line (°F)	130.4	SC (°F)	-19.3
Suct Press (psig)	88.6	Sat (°F)	25.7
Suct Temp (°F)	38.1	SH (°F)	12.4

**Electrical**

Est Power (kW)	20.3
Comp Run Hrs	1026.1

# Do you want more....?

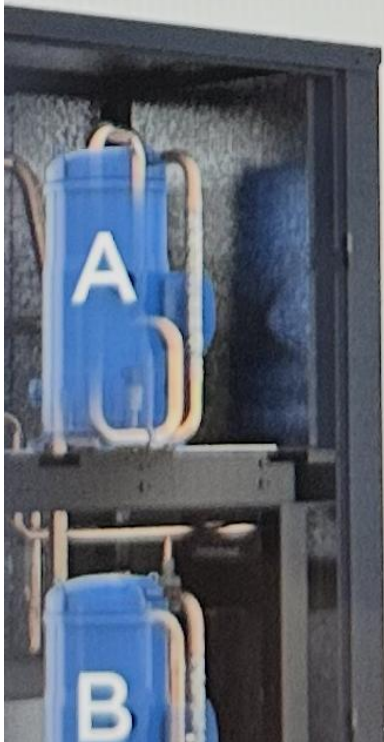

**Current Temperatures**

Load Inlet (°F)	47.4
Load Outlet (°F)	200.2
Source Inlet (°F)	38.1
Source Outlet (°F)	31.2

Model NXW360D3AEBNNRYJ  
Serial 231002188

**Circuit B**

Status	Active
Operation	Normal

**Refrigeration**

Disch Press (psig)	611.5	Sat (°F)	150.4
Liquid Line (°F)	131.4	SC (°F)	-19.2
Suct Press (psig)	88.9	Sat (°F)	25.9
Suct Temp (°F)	38.3	SH (°F)	12.4

**Electrical**

Est Power (kW)	20.4
Comp Run Hrs	1026.1

Please stop....!!!!

**Current Temperatures**

Load Inlet (°F)	47.6
Load Outlet (°F)	203.2
Source Inlet (°F)	38.3
Source Outlet (°F)	31.2

Model NXW360D3AEBNNRYJ  
Serial 231002188

**Circuit B**

Status	Active
Operation	Normal

**Refrigeration**

Disch Press (psig)	614.8	Sat (°F)	150.9
Liquid Line (°F)	132.8	SC (°F)	-18.1
Suct Press (psig)	89.4	Sat (°F)	26.2
Suct Temp (°F)	37.9	SH (°F)	11.6

**Electrical**

Est Power (kW)	20.5
Comp Run Hrs	1026.1



# Cold storage is desirable to make DHW more efficient

## EASTCHESTER 3

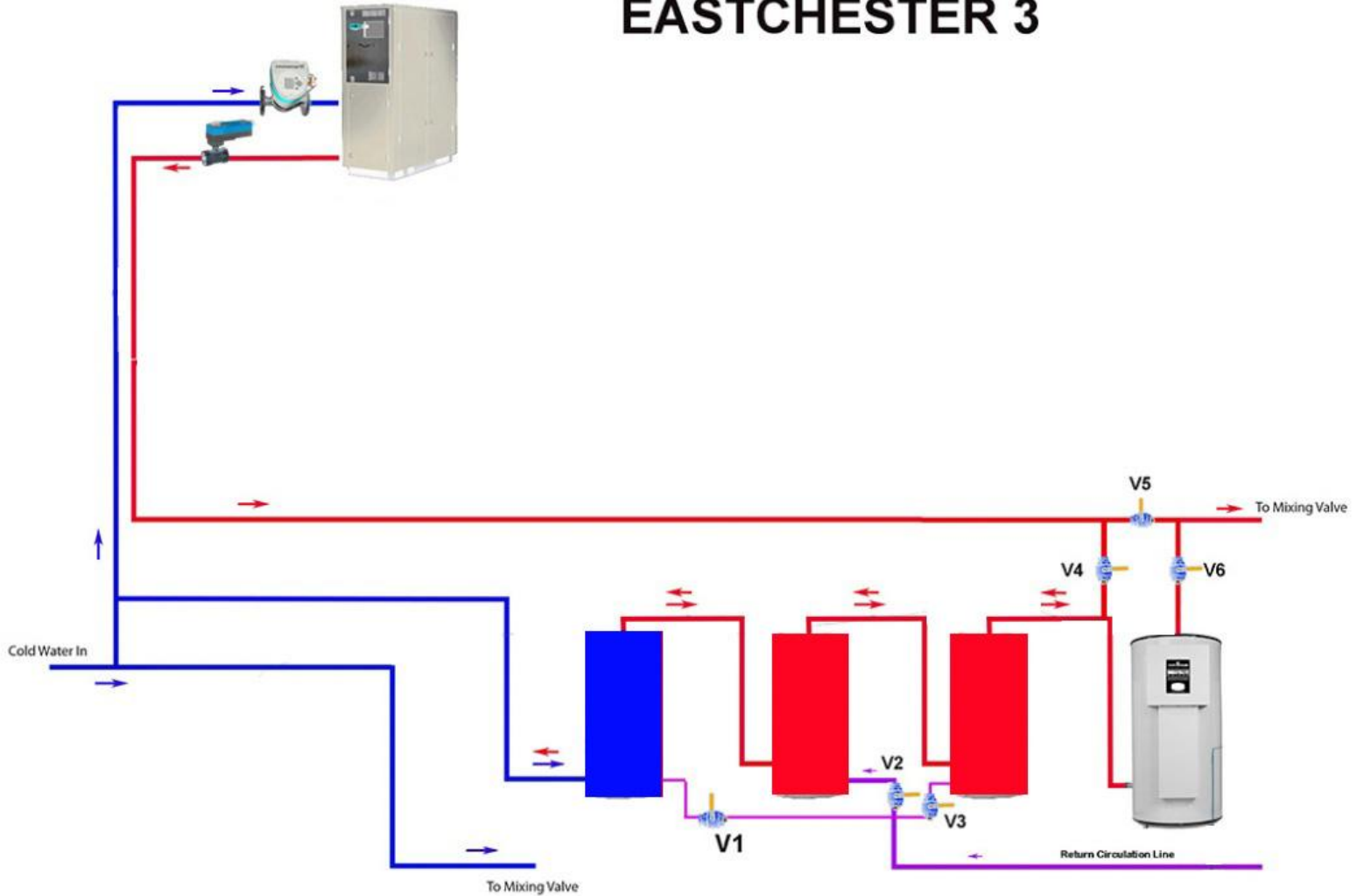

# Heat Extraction and Efficiency Evolvement NYCHA Eastchester 3

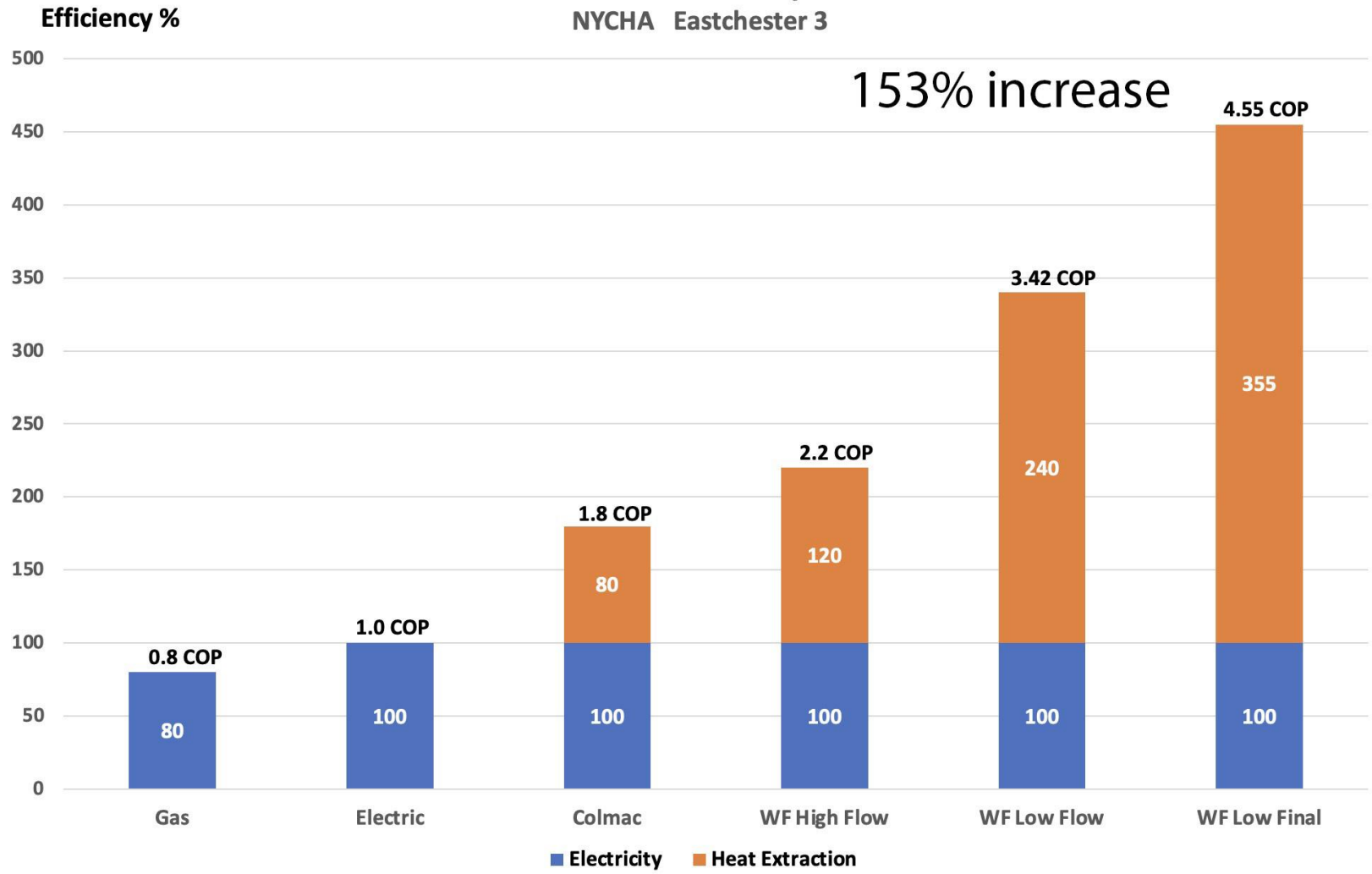



Loop field pumping power reduced by 90%

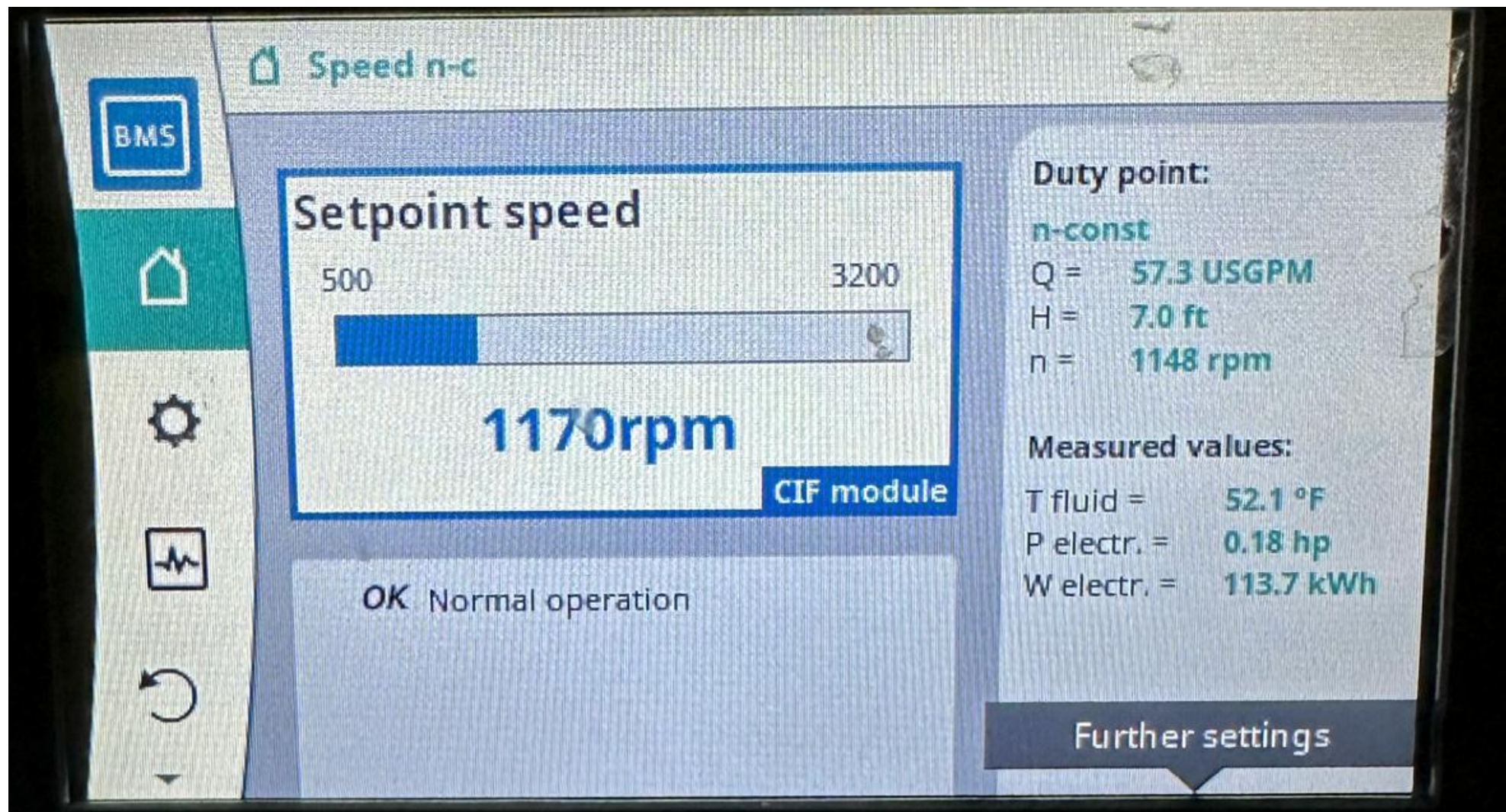

Heat Extraction from the loop field 394,000 vs 170,000 BTUs/h = 231% increase





Power consumption down from 41.3KW to 32.5KW = 21% decrease

Capacity is up from 311 MBTUH to 507 MBTUH = 63% increase



### HVAC Equipment

Project: NYCHA-DHW, New York  
 Contractor:   
 Engineer:   
 Representative: MWSK Equipment, New York  
 04-03-2023- Pending Approval

<b>Performance Summary - Unit 1, Tag</b>		TruClimate 100 Domestic Hot Water Chiller (NXW) 360 Model Nomenclature: NXW360D3AEBNNXXJ	383652-1
		Water-to-water heat pumps are an excellent choice to provide water heating and water cooling for a wide range of applications. Full Load-17.9 EER / 3.4 COP (ARI 13256-2 GLHP), Full Load-16.0 EER / 4.7 COP (ARI 13256-2 WLHP), Part Load-22.2 EER / 3.7 COP (ARI 13256-2 GLHP), Part Load-17.4 EER / 5.1 COP (ARI 13256-2 WLHP), 10 to 50 Ton, High volume hot water or chilled water.	
		  	

General Data				
<b>Voltage:</b> 208-230/60/3	Source Fluid / Antifreeze Type: Methanol	Source Fluid / Antifreeze %: 15.00	Load Fluid / Antifreeze Type: Water	Load Fluid / Antifreeze %: 0.00
Heating Data		Source	Load	
EWT		32.00 °F	130.00 °F	
LWT		26.17 °F	139.58 °F	
Flow		60.00 GPM	65.00 GPM	
PD		1.37 PSI 3.20 FTHD	1.80 PSI 4.20 FTHD	
<b>Power</b>	41.3 kW			
<b>COP</b>	2.2			
<b>Heat Extraction</b>	170.2 MBTUH			
<b>Heating Capacity</b>	311.2 MBTUH			

66.9	141.5	50.5	36	55.4	16.1	16.1	14.5	393617	109866.4	503483.4	4.58	13.498214	Stable
70.4	141.8	50.5	36.2	55.1	16.1	16.1	14.3	386085.7	109866.4	495952.1	4.51	13.892216	Stable
70.4	141.8	50.5	36	55.6	16.1	16.1	14.5	395038	109866.4	504904.4	4.60	14.14298	Stable
70.1	141.8	50.4	36	56.2	16.1	16.2	14.4	396547.2	110207.6	506754.8	4.60	14.13542	Stable
69.9	141.8	50.5	36	55.9	16.1	16.2	14.5	397169.5	110207.6	507377.1	4.60	14.11341	Stable
70.6	142.5	50.4	36.2	55.8	16.3	16.2	14.2	388256.4	110890	499146.4	4.50	13.884462	Stable
70.7	142.5	50.4	36.2	55.9	16.2	16.2	14.2	388952.2	110548.8	499501	4.52	13.913677	Stable
70.6	142.5	50.4	36	56.7	16.3	16.2	14.4	400075.2	110890	510965.2	4.61	14.213218	Stable
69.3	141.8	50.4	36.3	56.3	16.3	16.2	14.1	388976.7	110890	499866.7	4.51	13.789426	Stable
69.9	141.8	50.4	36	56	16.3	16.2	14.4	395136	110890	506026	4.56	14.075828	Stable
69.8	141.8	50.4	36	56.8	16.3	16.3	14.4	400780.8	111231.2	512012	4.60	14.222556	Stable

DHW pumping power reduced by (95%)



DHW pumping power reduced by (97%)



DHW pumping power reduced by (99%)



# Eastchester 3      Supply Temperatures

## 03-31-2025

### System operating as designed

HouseWaterTemperatures.png

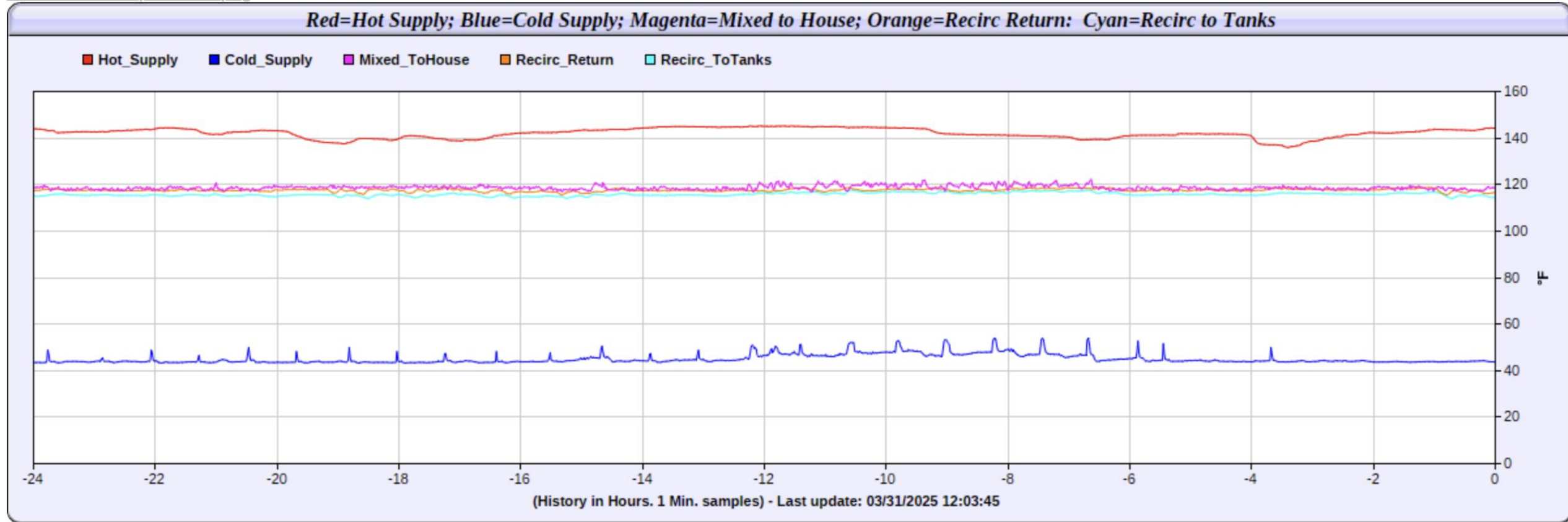

# Bottom Line - Jackson Houses

153% increase in efficiency compared to original design  
In-house control software development

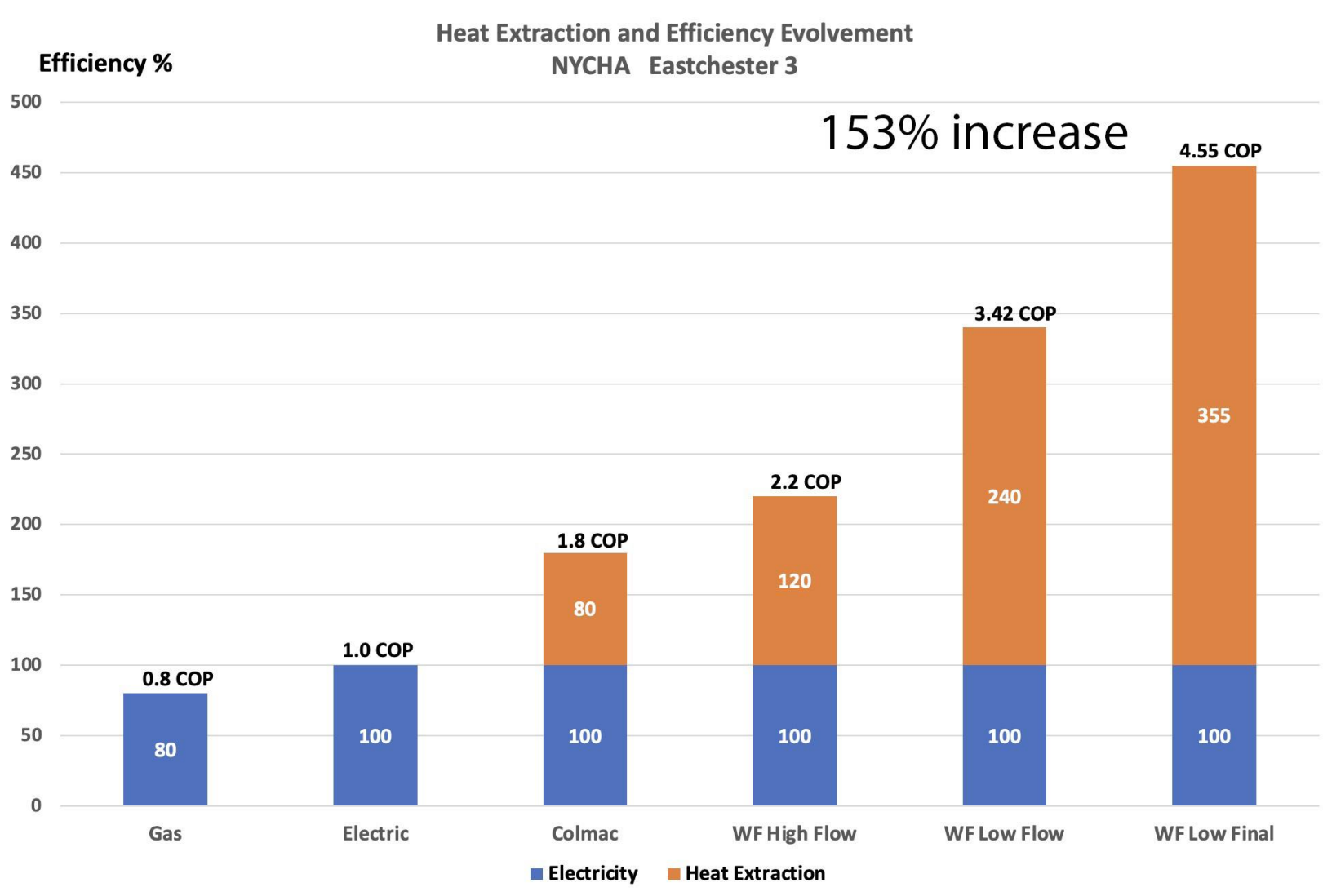

# ENR REGIONAL 2025 New York BEST PROJECTS



**BEST RESIDENTIAL/HOSPITALITY PROJECT**  
**NYCHA EASTCHESTER AND  
JACKSON HOUSES - GEOTHERMAL  
DHW AND HEATING UPGRADE**



# ENR REGIONAL 2025 New York BEST PROJECTS



**BEST PROJECT: EXCELLENCE IN SUSTAINABILITY**  
**NYCHA EASTCHESTER AND  
JACKSON HOUSES - GEOTHERMAL  
DHW AND HEATING UPGRADE**





**NY - GEO 2026**  
March 24-25, 2026 | Brooklyn, NY



# Innovative Domestic Hot Water Approach

## Speakers:

Hugh Hendersen / *Owahgena Consulting, Inc.*

Jens Ponikau / *Buffalo Geothermal*